

**ST LM358N**

<b>Order Code</b>	<b>Manufacturers Part No</b>	<b>Description</b>
560-070	LM358N	Dual Op Amp

RoHS compliant

The enclosed information is believed to be correct. Information may change without notice due to product improvement. Check to ensure that the product is suitable for the intended application. E. and O.E

**Telephone**      **01737 841568**  
**FAX**              **01737 841608**  
**Email**            [technical@electronelec.co.uk](mailto:technical@electronelec.co.uk)  
**Web**              [www.electronelec.co.uk](http://www.electronelec.co.uk)

## Low power dual operational amplifiers

### Features

- Internally frequency compensated
- Large DC voltage gain: 100 dB
- Wide bandwidth (unity gain): 1.1 MHz (temperature compensated)
- Very low supply current per operator essentially independent of supply voltage
- Low input bias current: 20 nA (temperature compensated)
- Low input offset voltage: 2 mV
- Low input offset current: 2 nA
- Input common-mode voltage range includes negative rails
- Differential input voltage range equal to the power supply voltage
- Large output voltage swing 0 V to  $(V_{CC}^+ - 1.5V)$

### Description

These circuits consist of two independent, high-gain, internally frequency-compensated op-amps which are designed specifically to operate from a single power supply over a wide range of voltages. The low power supply drain is independent of the magnitude of the power supply voltage.

Application areas include transducer amplifiers, DC gain blocks and all the conventional op-amp circuits which now can be more easily implemented in single power supply systems. For example, these circuits can be directly supplied with the standard +5 V which is used in logic systems and will easily provide the required interface electronics without requiring any additional power supply.

In linear mode, the input common-mode voltage range includes ground and the output voltage can also swing to ground, even though operated from only a single power supply voltage.

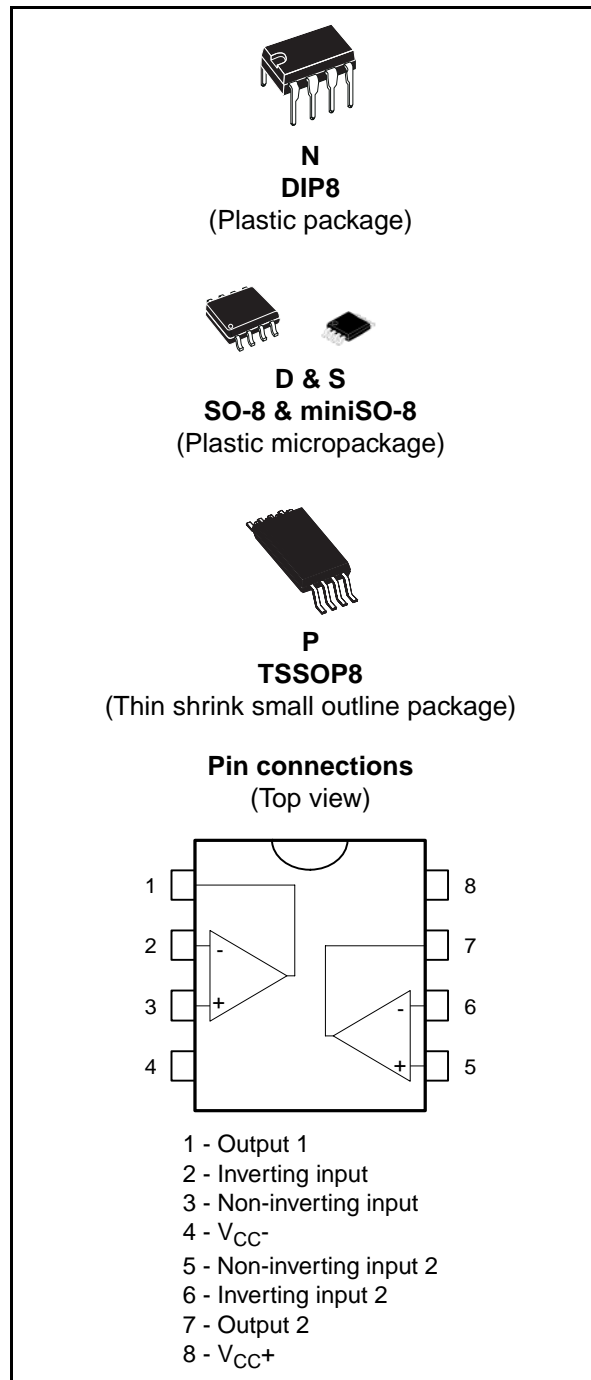

# 1 Schematic diagram

Figure 1. Schematic diagram (1/2 LM158)

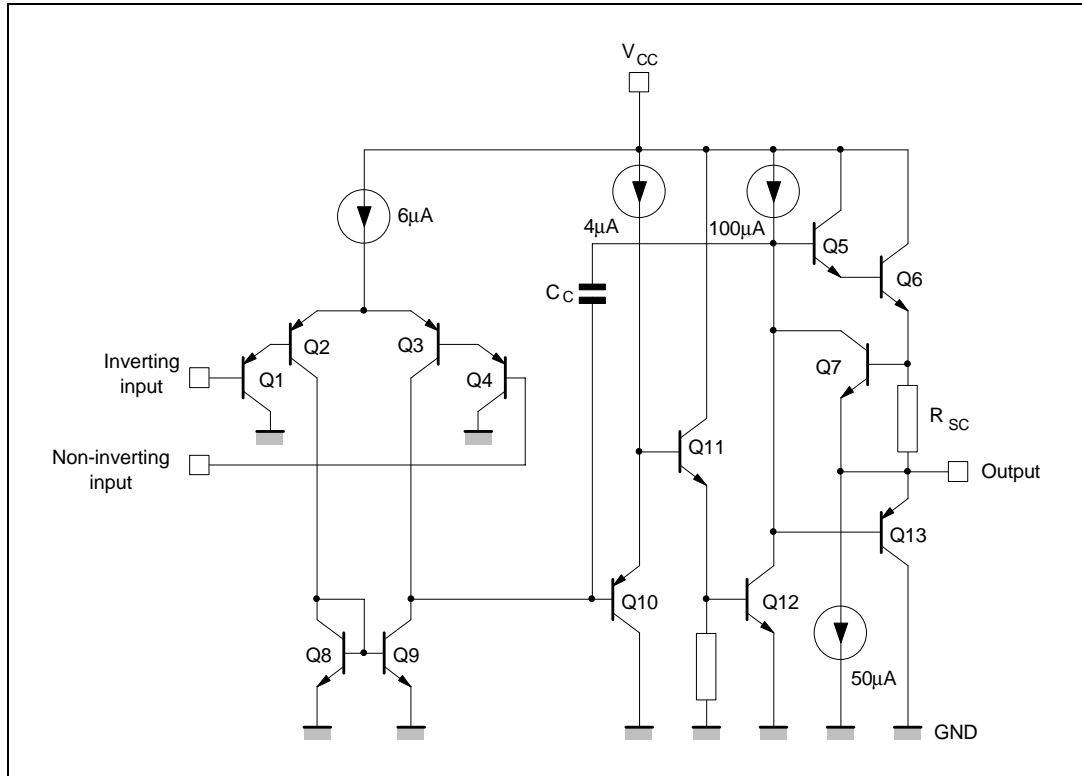

## 2 Absolute maximum ratings

**Table 1. Absolute maximum ratings**

Symbol	Parameter	LM158,A	LM258,A	LM358,A	Unit
$V_{CC}$	Supply voltage	+/-16 or 32			V
$V_i$	Input voltage	32			V
$V_{id}$	Differential input voltage	32			V
	Output short-circuit duation <sup>(1)</sup>	Infinite			
$I_{in}$	Input current <sup>(2)</sup>	50			mA
$T_{oper}$	Operating free-air temperature range	-55 to +125	-40 to +105	0 to +70	°C
$T_{stg}$	Storage temperature range	-65 to +150			°C
$T_j$	Maximum junction temperature	150			°C
$R_{thja}$	Thermal resistance junction to ambient <sup>(3)</sup>				°C/W
	SO-8	125			
	MiniSO-8	190			
	TSSOP8	120			
$R_{thjc}$	Thermal resistance junction to case <sup>(3)</sup>				°C/W
	SO-8	40			
	MiniSO-8	39			
	TSSOP8	37			
ESD	HBM: human body model <sup>(4)</sup>	300			V
	MM: machine model <sup>(5)</sup>	200			V
	CDM: charged device model <sup>(6)</sup>	1.5			kV

- Short-circuits from the output to  $V_{CC}$  can cause excessive heating if  $V_{CC} > 15$  V. The maximum output current is approximately 40 mA independent of the magnitude of  $V_{CC}$ . Destructive dissipation can result from simultaneous short-circuits on all amplifiers.
- This input current only exists when the voltage at any of the input leads is driven negative. It is due to the collector-base junction of the input PNP transistor becoming forward biased and thereby acting as input diode clamps. In addition to this diode action, there is also NPN parasitic action on the IC chip. This transistor action can cause the output voltages of the Op-amps to go to the  $V_{CC}$  voltage level (or to ground for a large overdrive) for the time during which an input is driven negative. This is not destructive and normal output is restored for input voltages above -0.3 V.
- Short-circuits can cause excessive heating and destructive dissipation.  $R_{th}$  are typical values.
- Human body model: A 100pF capacitor is charged to the specified voltage, then discharged through a 1.5k $\Omega$  resistor between two pins of the device. This is done for all couples of connected pin combinations while the other pins are floating.
- Machine model: A 200pF capacitor is charged to the specified voltage, then discharged directly between two pins of the device with no external series resistor (internal resistor < 5 $\Omega$ ). This is done for all couples of connected pin combinations while the other pins are floating.
- Charged device model: all pins and the package are charged together to the specified voltage and then discharged directly to the ground through only one pin. This is done for all pins.

### 3 Operating conditions

**Table 2. Operating conditions**

Symbol	Parameter	Value	Unit
$V_{CC}$	Supply voltage	3 to 30	V
$V_{icm}$	Common mode input voltage range	$V_{CC}^- - 0.3$ to $V_{CC}^+ - 1.5$	V
$T_{oper}$	Operating free air temperature range LM158 LM258 LM358	-55 to +125 -40 to +105 0 to +70	°C

## 4 Electrical characteristics

**Table 3. Electrical characteristics for  $V_{CC}^+ = +5V$ ,  $V_{CC}^- = \text{Ground}$ ,  $V_o = 1.4V$ ,  $T_{\text{amb}} = +25^\circ\text{C}$  (unless otherwise specified)**

Symbol	Parameter	Min.	Typ.	Max.	Unit
$V_{io}$	Input offset voltage <sup>(1)</sup> LM158A LM258A, LM358A LM158, LM258 LM358		1 2	2 3 5 7	mV
	$T_{\text{min}} \leq T_{\text{amb}} \leq T_{\text{max}}$ LM158A, LM258A, LM358A LM158, LM258 LM358			4 7 9	
$DV_{io}$	Input offset voltage drift LM158A, LM258A, LM358A LM158, LM258, LM358		7 7	15 30	$\mu\text{V}/^\circ\text{C}$
$I_{io}$	Input offset current LM158A, LM258A, LM358A LM158, LM258, LM358		2 2	10 30	nA
	$T_{\text{min}} \leq T_{\text{amb}} \leq T_{\text{max}}$ LM158A, LM258A, LM358A LM158, LM258, LM358			30 40	
$DI_{io}$	Input offset current drift LM158A, LM258A, LM358A LM158, LM258, LM358		10 10	200 300	$\text{pA}/^\circ\text{C}$
$I_{ib}$	Input bias current <sup>(2)</sup> LM158A, LM258A, LM358A LM158, LM258, LM358		20 20	50 150	nA
	$T_{\text{min}} \leq T_{\text{amb}} \leq T_{\text{max}}$ LM158A, LM258A, LM358A LM158, LM258, LM358			100 200	
$A_{vd}$	Large signal voltage gain $V_{CC}^+ = +15\text{ V}$ , $R_L = 2\text{ k}\Omega$ , $V_o = 1.4\text{ V to } 11.4\text{ V}$ $T_{\text{min}} \leq T_{\text{amb}} \leq T_{\text{max}}$	50 25	100		V/mV
SVR	Supply voltage rejection ratio $V_{CC}^+ = 5\text{ V to } 30\text{ V}$ , $R_s \leq 10\text{ k}\Omega$ $T_{\text{min}} \leq T_{\text{amb}} \leq T_{\text{max}}$	65 65	100		dB
$I_{CC}$	Supply current, all amp, no load $T_{\text{min}} \leq T_{\text{amb}} \leq T_{\text{max}}$ $V_{CC}^+ = +5\text{ V}$ $T_{\text{min}} \leq T_{\text{amb}} \leq T_{\text{max}}$ $V_{CC}^+ = +30\text{ V}$		0.7	1.2 2	mA
$V_{icm}$	Input common mode voltage range $V_{CC}^+ = +30\text{ V}$ <sup>(3)</sup> $T_{\text{min}} \leq T_{\text{amb}} \leq T_{\text{max}}$	0 0		$V_{CC}^+ - 1.5$ $V_{CC}^+ - 2$	V

**Table 3. Electrical characteristics for  $V_{CC}^+ = +5V$ ,  $V_{CC}^- = \text{Ground}$ ,  $V_o = 1.4V$ ,  $T_{amb} = +25^\circ C$  (unless otherwise specified)**

Symbol	Parameter	Min.	Typ.	Max.	Unit
CMR	Common mode rejection ratio				
	$R_s \leq 10 \text{ k}\Omega$ $T_{min} \leq T_{amb} \leq T_{max}$	70 60	85		dB
$I_{source}$	Output current source $V_{CC}^+ = +15 \text{ V}$ , $V_o = +2 \text{ V}$ , $V_{id} = +1 \text{ V}$	20	40	60	mA
$I_{sink}$	Output sink current				
	$V_{CC}^+ = +15V$ , $V_o = +2V$ , $V_{id} = -1V$ $V_{CC}^+ = +15V$ , $V_o = +0.2V$ , $V_{id} = -1V$	10 12	20 50		mA $\mu A$
$V_{OH}$	High level output voltage				
	$R_L = 2 \text{ k}\Omega$ , $V_{CC}^+ = 30 \text{ V}$	26	27		V
	$T_{min} \leq T_{amb} \leq T_{max}$	26			
	$R_L = 10 \text{ k}\Omega$ , $V_{CC}^+ = 30 \text{ V}$	27	28		
$T_{min} \leq T_{amb} \leq T_{max}$	27				
$V_{OL}$	Low level output voltage $R_L = 10 \text{ k}\Omega$ $T_{min} \leq T_{amb} \leq T_{max}$		5	20 20	mV
SR	Slew rate $V_{CC}^+ = 15V$ , $V_i = 0.5 \text{ to } 3V$ , $R_L = 2k\Omega$ , $C_L = 100pF$ , unity Gain	0.3	0.6		V/ $\mu s$
GBP	Gain bandwidth product $V_{CC}^+ = 30 \text{ V}$ , $f = 100 \text{ kHz}$ , $V_{in} = 10 \text{ mV}$ , $R_L = 2 \text{ k}\Omega$ , $C_L = 100 \text{ pF}$	0.7	1.1		MHz
THD	Total harmonic distortion $f = 1 \text{ kHz}$ , $A_v = 20 \text{ dB}$ , $R_L = 2 \text{ k}\Omega$ , $V_o = 2 V_{pp}$ , $C_L = 100 \text{ pF}$ , $V_o = 2 V_{pp}$		0.02		%
$e_n$	Equivalent input noise voltage $f = 1 \text{ kHz}$ , $R_s = 100 \Omega$ , $V_{CC}^+ = 30 \text{ V}$		55		$\frac{nV}{\sqrt{Hz}}$
$V_{o1}/V_{o2}$	Channel separation <sup>(4)</sup> $1 \text{ kHz} \leq f \leq 20 \text{ kHz}$		120		dB

- $V_o = 1.4 \text{ V}$ ,  $R_s = 0 \Omega$ ,  $5 \text{ V} < V_{CC}^+ < 30 \text{ V}$ ,  $0 < V_{ic} < V_{CC}^+ - 1.5 \text{ V}$
- The direction of the input current is out of the IC. This current is essentially constant, independent of the state of the output so there is no change in the load on the input lines.
- The input common-mode voltage of either input signal voltage should not be allowed to go negative by more than 0.3 V. The upper end of the common-mode voltage range is  $V_{CC}^+ - 1.5 \text{ V}$ , but either or both inputs can go to +32 V without damage.
- Due to the proximity of external components, ensure that stray capacitance between these external parts does not cause coupling. Typically, this can be detected because this type of capacitance increases at higher frequencies.

Figure 2. Open loop frequency response

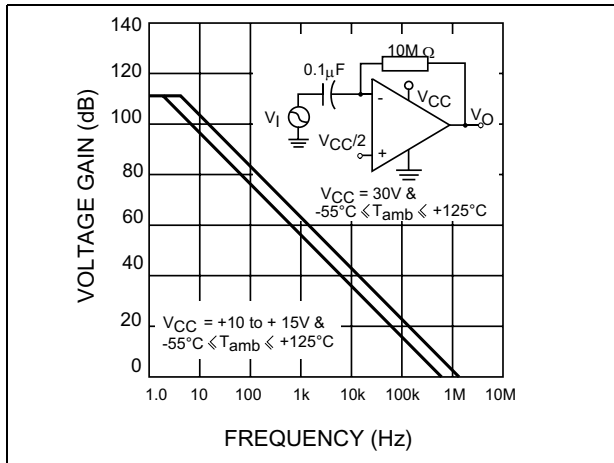

Figure 3. Large signal frequency response

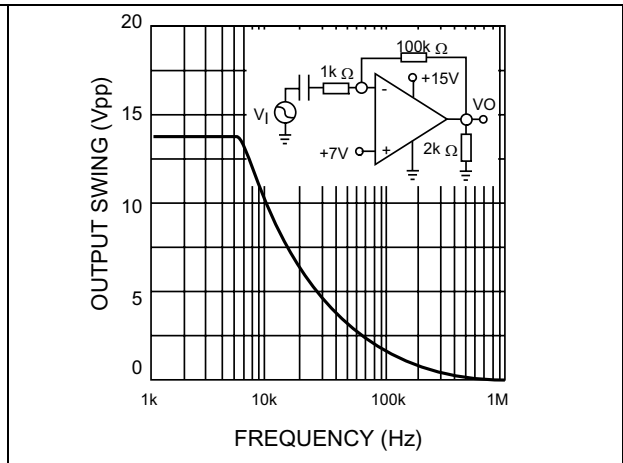

Figure 4. Voltage follower pulse response

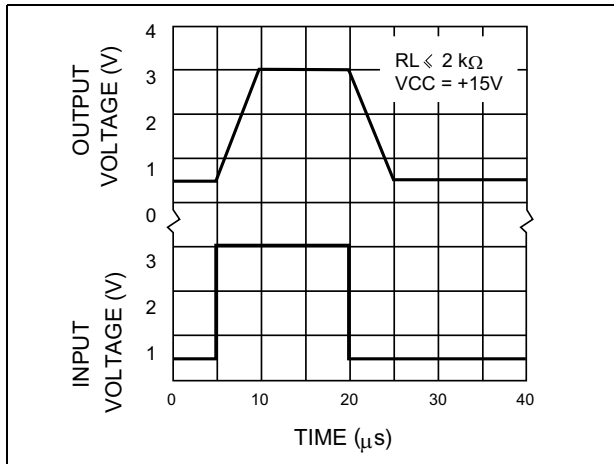

Figure 5. Voltage follower pulse response

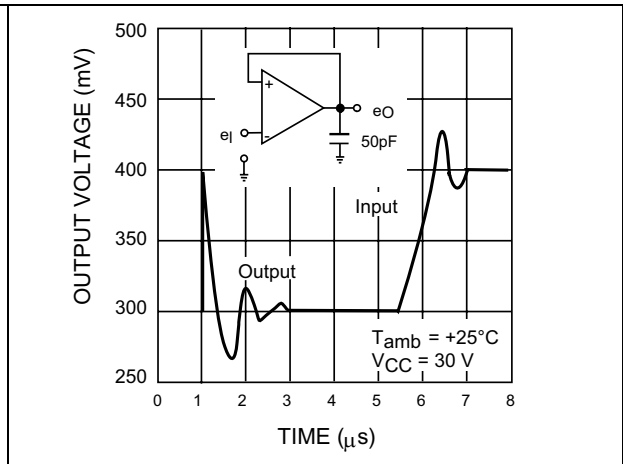

Figure 6. Input current

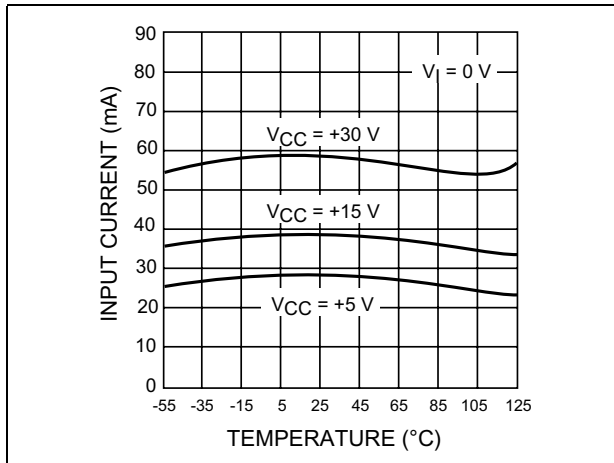

Figure 7. Output characteristics

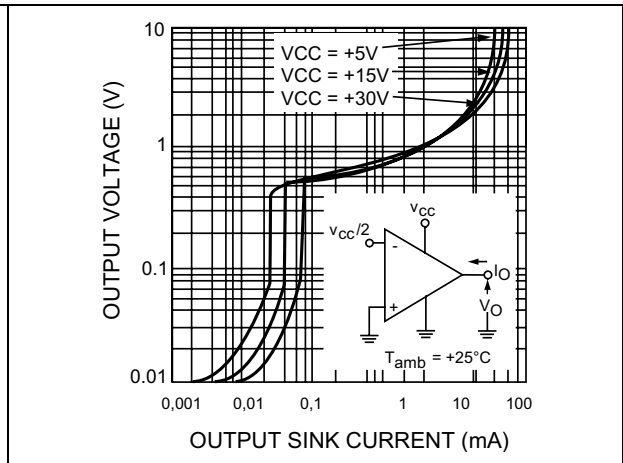

Figure 8. Output characteristics

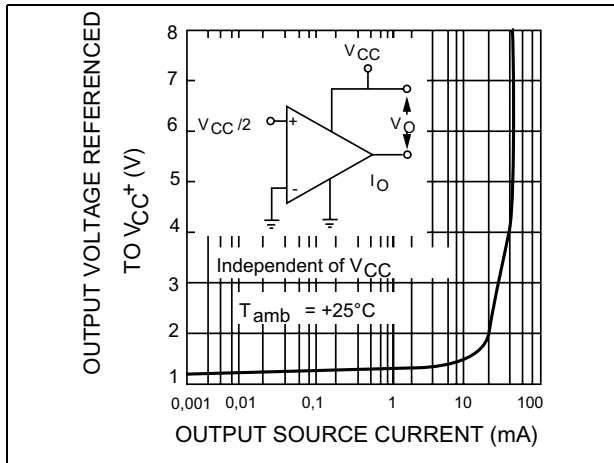

Figure 9. Current limiting

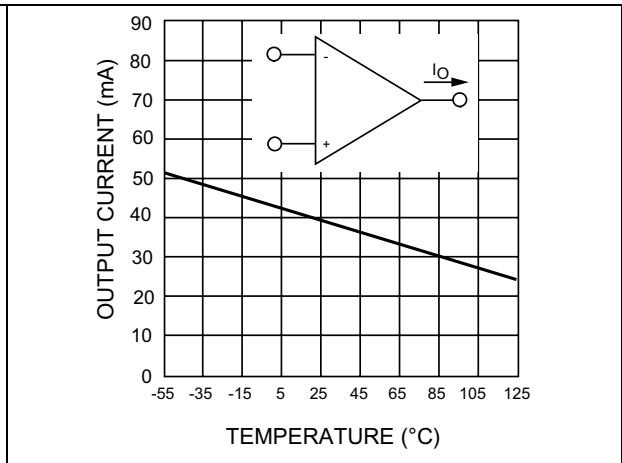

Figure 10. Input voltage range

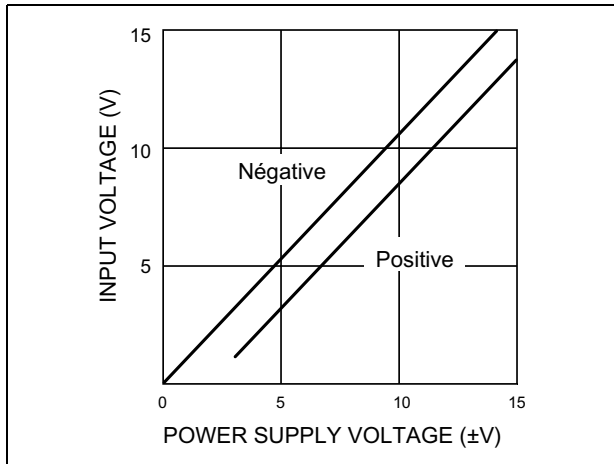

Figure 11. Positive supply voltage

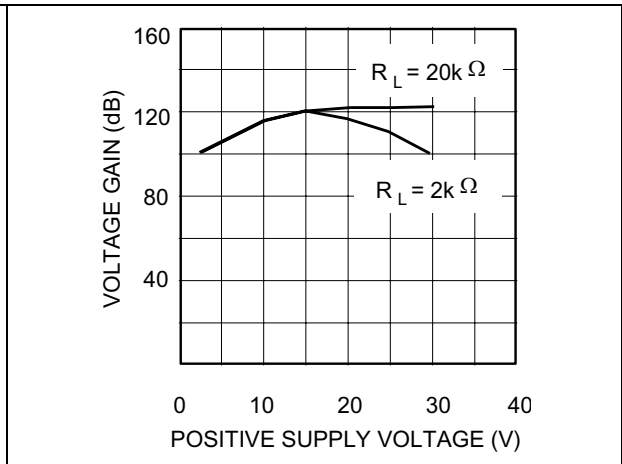

Figure 12. Input voltage range

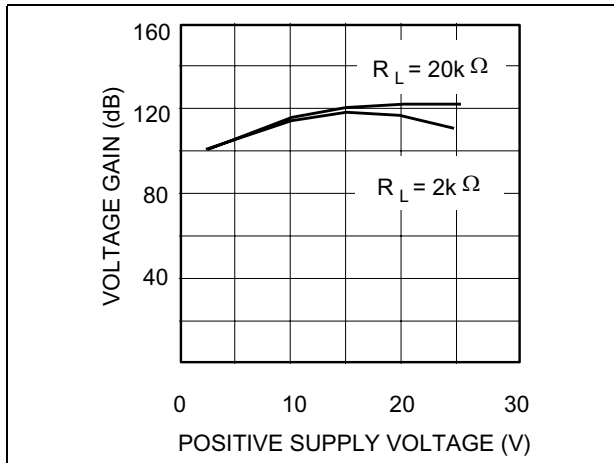

Figure 13. Supply current

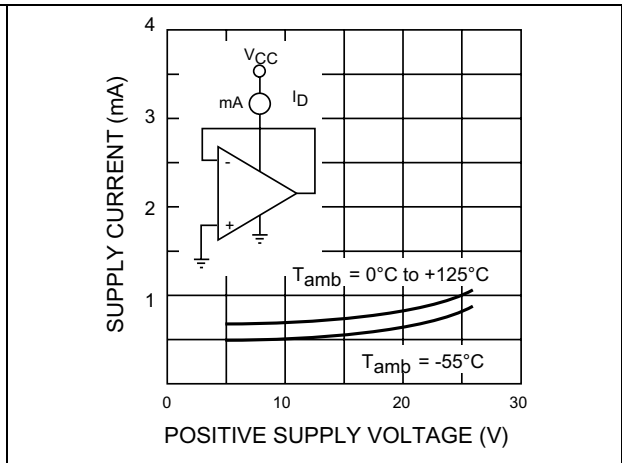

Figure 14. Input current

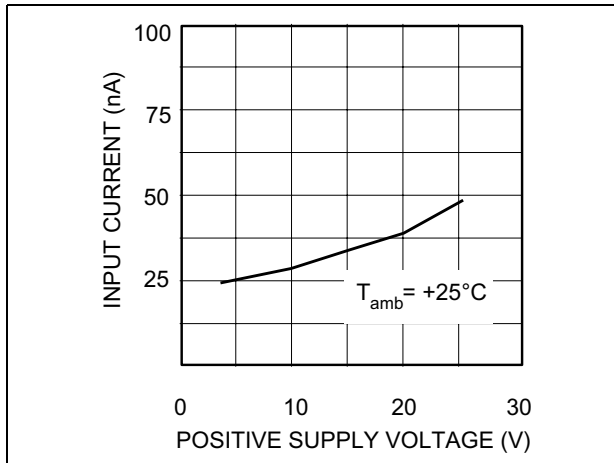

Figure 15. Gain bandwidth product

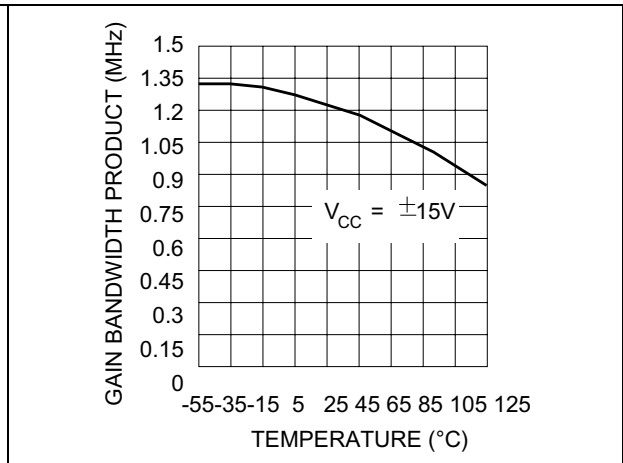

Figure 16. Power supply rejection ratio

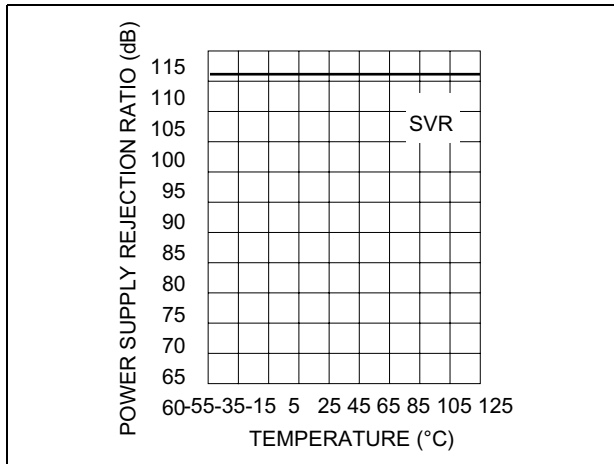

Figure 17. Common mode rejection ratio

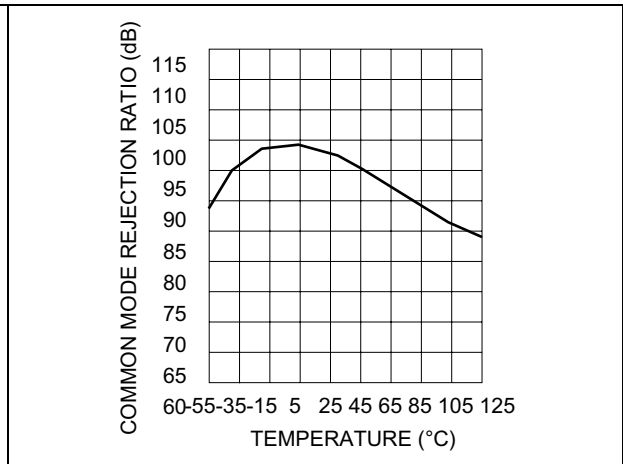
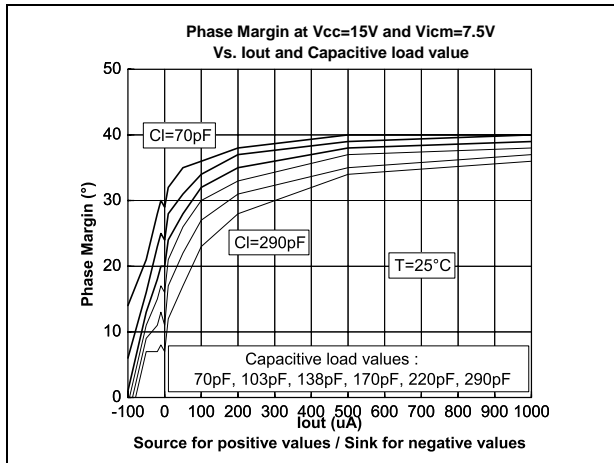

Figure 18. Phase margin vs. capacitive load



# 5 Typical applications

Single supply voltage  $V_{CC} = +5V_{DC}$ .

**Figure 19. AC coupled inverting amplifier**

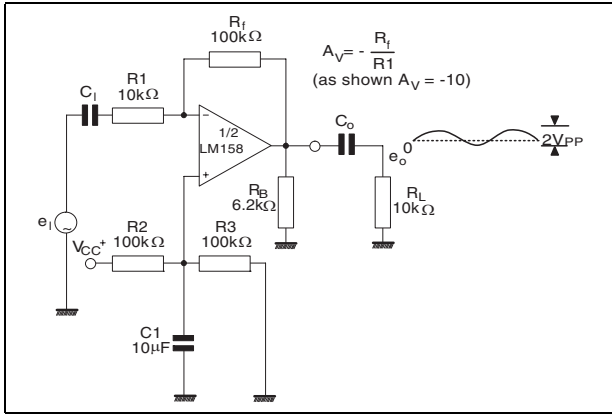

**Figure 20. Non-inverting DC amplifier**

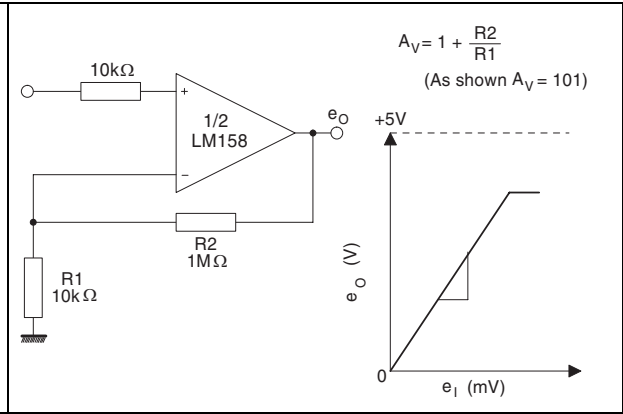

**Figure 21. AC coupled non-inverting amplifier**

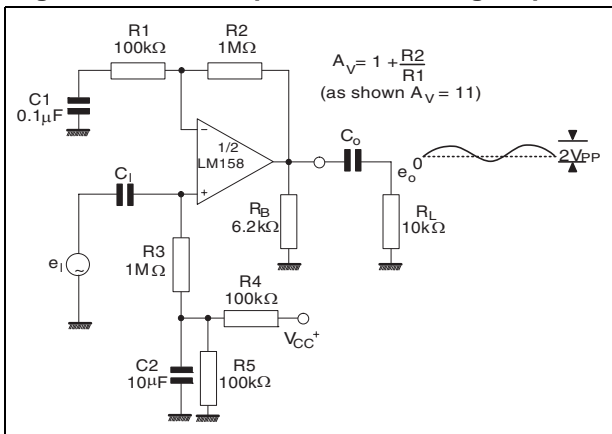

**Figure 22. DC summing amplifier**

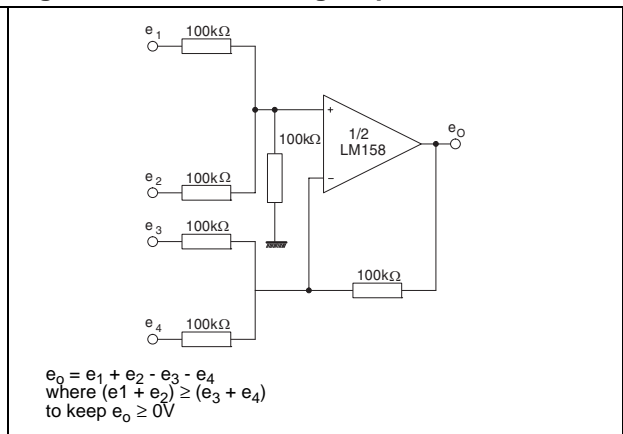

**Figure 23. High input Z, DC differential amplifier**

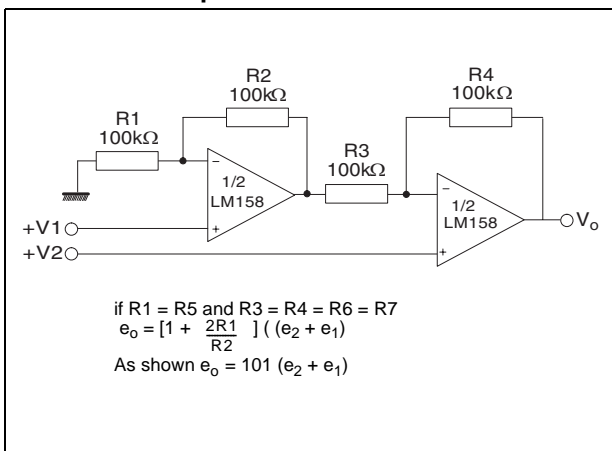

**Figure 24. High input Z adjustable gain DC instrumentation amplifier**

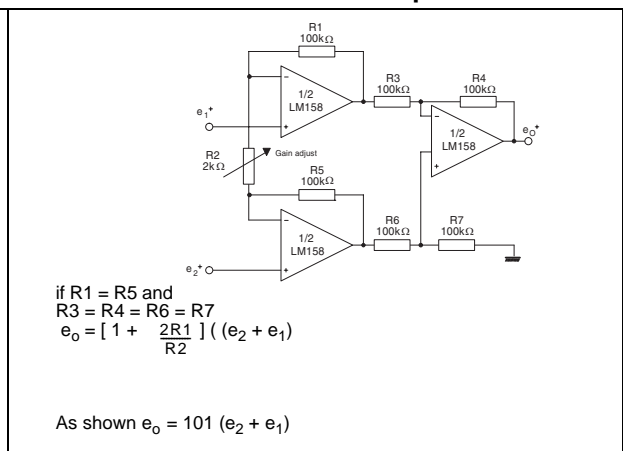

Figure 25. Using symmetrical amplifiers to reduce input current

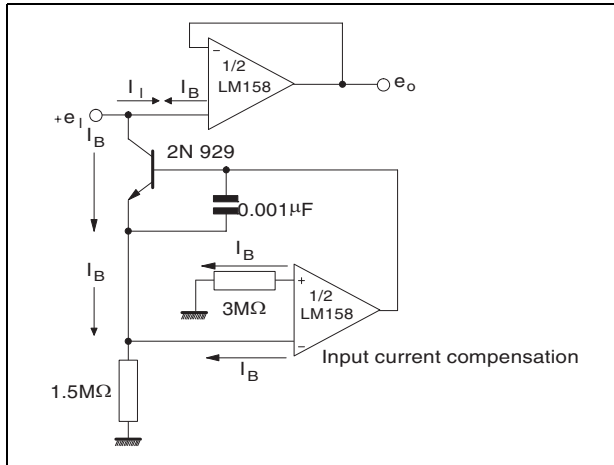

Figure 26. Low drift peak detector

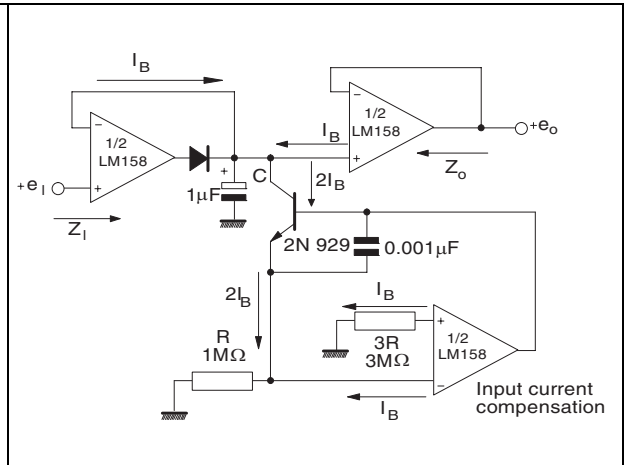
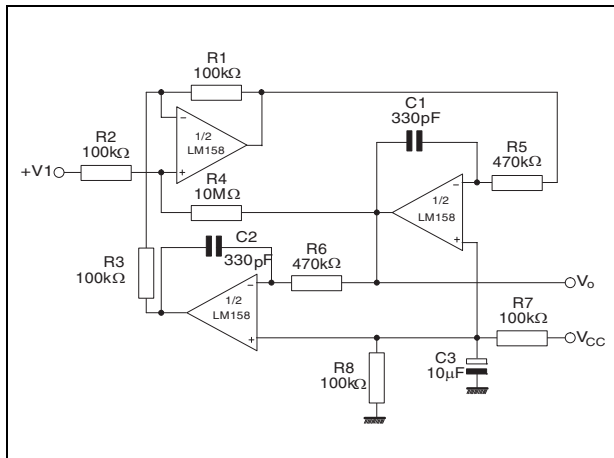

Figure 27. Active band-pass filter



## 6 Package information

In order to meet environmental requirements, STMicroelectronics offers these devices in ECOPACK<sup>®</sup> packages. These packages have a lead-free second level interconnect. The category of second level interconnect is marked on the package and on the inner box label, in compliance with JEDEC Standard JESD97. The maximum ratings related to soldering conditions are also marked on the inner box label. ECOPACK is an STMicroelectronics trademark. ECOPACK specifications are available at: [www.st.com](http://www.st.com).

### 6.1 DIP8 package information

Figure 28. DIP8 package mechanical drawing

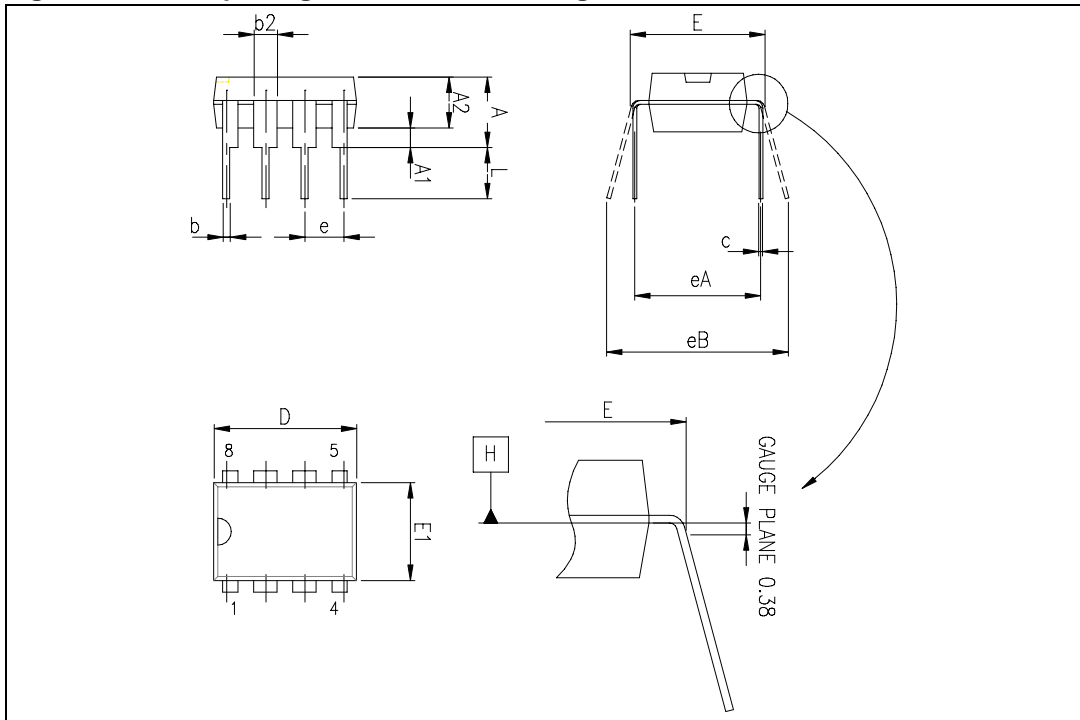

Table 4. DIP8 package mechanical data

Ref.	Dimensions					
	Millimeters			Inches		
	Min.	Typ.	Max.	Min.	Typ.	Max.
A			5.33			0.210
A1	0.38			0.015		
A2	2.92	3.30	4.95	0.115	0.130	0.195
b	0.36	0.46	0.56	0.014	0.018	0.022
b2	1.14	1.52	1.78	0.045	0.060	0.070
c	0.20	0.25	0.36	0.008	0.010	0.014
D	9.02	9.27	10.16	0.355	0.365	0.400
E	7.62	7.87	8.26	0.300	0.310	0.325
E1	6.10	6.35	7.11	0.240	0.250	0.280
e		2.54			0.100	
eA		7.62			0.300	
eB			10.92			0.430
L	2.92	3.30	3.81	0.115	0.130	0.150

## 6.2 SO-8 package information

Figure 29. SO-8 package mechanical drawing

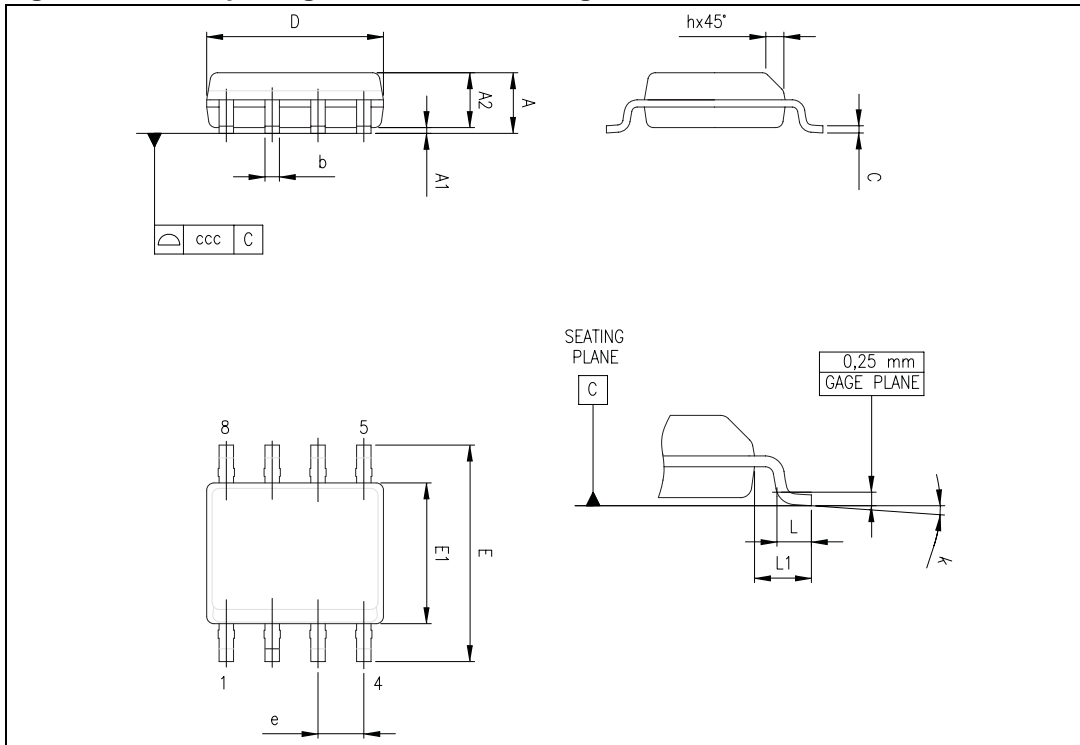

Table 5. SO-8 package mechanical data

Ref.	Dimensions					
	Millimeters			Inches		
	Min.	Typ.	Max.	Min.	Typ.	Max.
A			1.75			0.069
A1	0.10		0.25	0.004		0.010
A2	1.25			0.049		
b	0.28		0.48	0.011		0.019
c	0.17		0.23	0.007		0.010
D	4.80	4.90	5.00	0.189	0.193	0.197
H	5.80	6.00	6.20	0.228	0.236	0.244
E1	3.80	3.90	4.00	0.150	0.154	0.157
e		1.27			0.050	
h	0.25		0.50	0.010		0.020
L	0.40		1.27	0.016		0.050
k	1°		8°	1°		8°
ccc			0.10			0.004

## 6.3 MiniSO-8 package information

Figure 30. MiniSO-8 package mechanical drawing

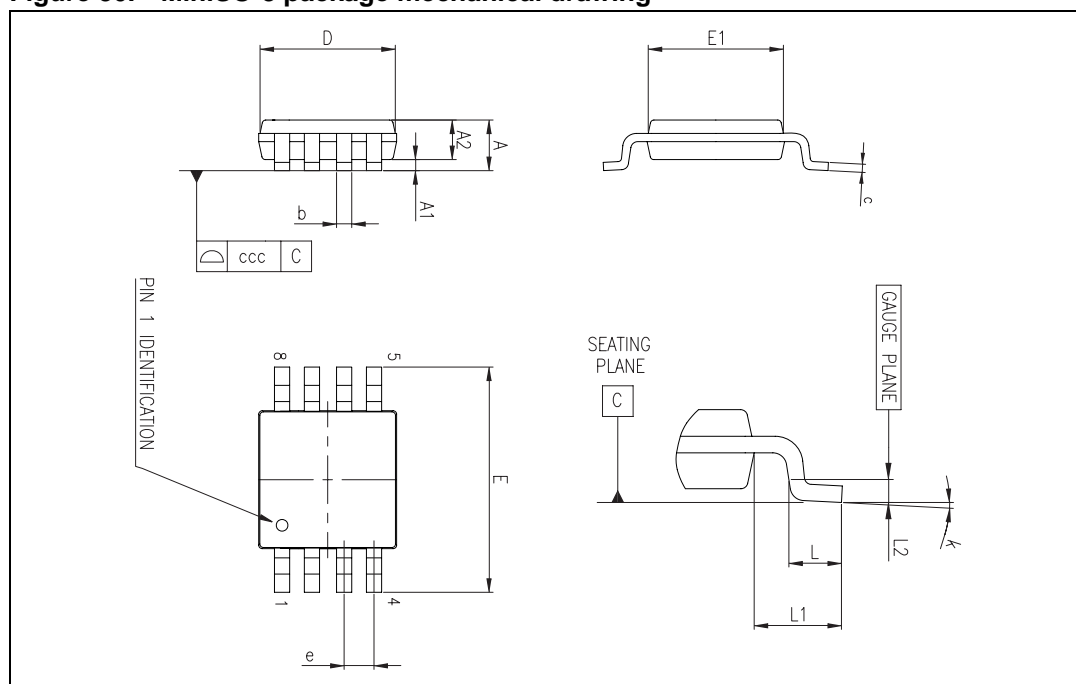

Table 6. MiniSO-8 package mechanical data

Ref.	Dimensions					
	Millimeters			Inches		
	Min.	Typ.	Max.	Min.	Typ.	Max.
A			1.1			0.043
A1	0		0.15	0		0.006
A2	0.75	0.85	0.95	0.030	0.033	0.037
b	0.22		0.40	0.009		0.016
c	0.08		0.23	0.003		0.009
D	2.80	3.00	3.20	0.11	0.118	0.126
E	4.65	4.90	5.15	0.183	0.193	0.203
E1	2.80	3.00	3.10	0.11	0.118	0.122
e		0.65			0.026	
L	0.40	0.60	0.80	0.016	0.024	0.031
L1		0.95			0.037	
L2		0.25			0.010	
k	0°		8°	0°		8°
ccc			0.10			0.004

### 6.4 TSSOP8 package information

Figure 31. TSSOP8 package mechanical drawing

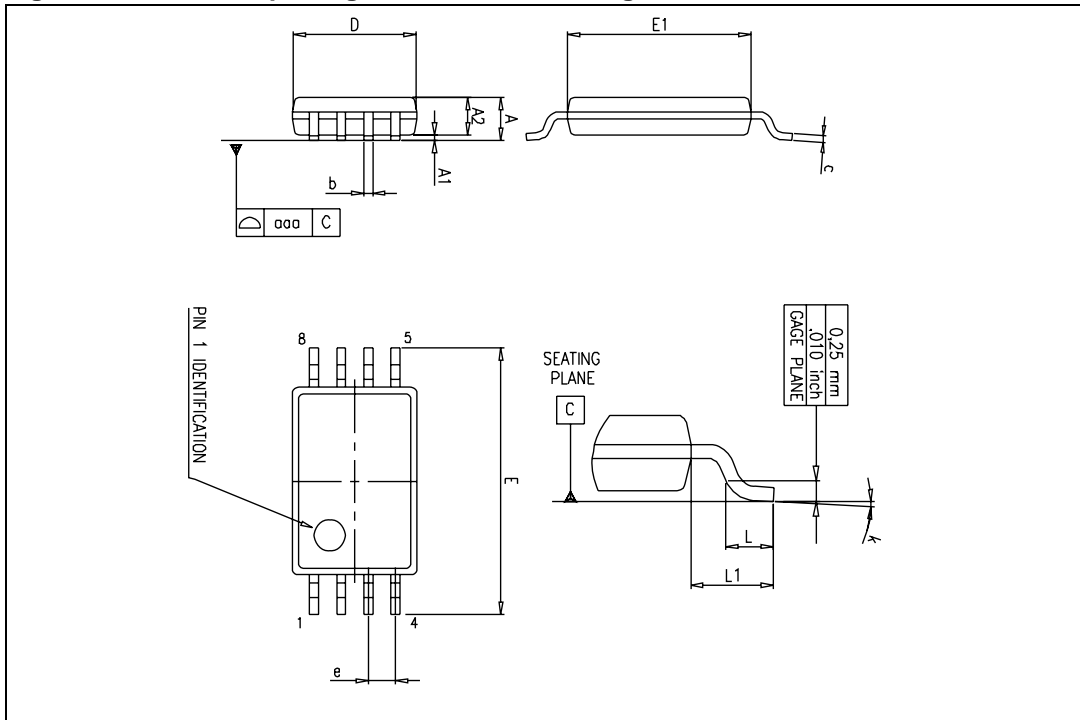

Table 7. TSSOP8 package mechanical data

Ref.	Dimensions					
	Millimeters			Inches		
	Min.	Typ.	Max.	Min.	Typ.	Max.
A			1.2			0.047
A1	0.05		0.15	0.002		0.006
A2	0.80	1.00	1.05	0.031	0.039	0.041
b	0.19		0.30	0.007		0.012
c	0.09		0.20	0.004		0.008
D	2.90	3.00	3.10	0.114	0.118	0.122
E	6.20	6.40	6.60	0.244	0.252	0.260
E1	4.30	4.40	4.50	0.169	0.173	0.177
e		0.65			0.0256	
k	0°		8°	0°		8°
L	0.45	0.60	0.75	0.018	0.024	0.030
L1		1			0.039	
aaa		0.1			0.004	

## 7 Ordering information

**Table 8. Order codes**

Order code	Temperature range	Package	Packaging	Marking
LM158N	-55°C, +125°C	DIP8	Tube	LM158N
LM158D LM158DT		SO-8	Tube or tape & reel	158
LM158YD <sup>(1)</sup> LM158YDT <sup>(1)</sup>		SO-8 Automotive grade		158Y
LM258AN	-40°C, +105°C	DIP8	Tube	LM258A
LM258AD LM258ADT		SO-8	Tube or tape & reel	258A
LM258AYD <sup>(1)</sup> LM258AYDT <sup>(1)</sup>		SO-8 Automotive grade		258AY
LM258PT LM258APT		TSSOP8		Tape & reel
LM258YPT <sup>(2)</sup> LM258AYPT <sup>(2)</sup>		TSSOP8 Automotive grade	258A	
LM258AST		MiniSO-8	258Y	
LM258N		DIP8	258AY	
LM258D LM258DT		SO-8	Tube or tape & reel	K408
LM258YD <sup>(1)</sup> LM258YDT <sup>(1)</sup>		SO-8 Automotive grade		258
LM358N LM358AN		DIP8		Tube
LM358D LM358DT	SO-8	Tube or tape & reel	258	
LM358YD <sup>(1)</sup> LM358YDT <sup>(1)</sup>	SO-8 Automotive grade		258Y	
LM358AD LM358ADT	SO-8		358A	
LM358PT LM358APT	TSSOP8		Tape & reel	358
LM358YPT <sup>(2)</sup> LM358AYPT <sup>(2)</sup>	TSSOP8 Automotive grade	358A		
LM358ST LM358AST	MiniSO-8	358Y		
LM358N LM358AN	0°C, +70°C	DIP8	Tube	LM358N
LM358D LM358DT		SO-8	Tube or tape & reel	LM358AN
LM358YD <sup>(1)</sup> LM358YDT <sup>(1)</sup>		SO-8 Automotive grade		358
LM358AD LM358ADT		SO-8		358Y
LM358PT LM358APT		TSSOP8		Tape & reel
LM358YPT <sup>(2)</sup> LM358AYPT <sup>(2)</sup>		TSSOP8 Automotive grade	358	
LM358ST LM358AST		MiniSO-8	358A	
LM358N LM358AN		DIP8	Tube	LM358N
LM358D LM358DT	SO-8	Tube or tape & reel	LM358AN	
LM358YD <sup>(1)</sup> LM358YDT <sup>(1)</sup>	SO-8 Automotive grade		358	
LM358AD LM358ADT	SO-8		358Y	
LM358PT LM358APT	TSSOP8		Tape & reel	358A
LM358YPT <sup>(2)</sup> LM358AYPT <sup>(2)</sup>	TSSOP8 Automotive grade	358		
LM358ST LM358AST	MiniSO-8	358Y		
LM358N LM358AN	DIP8	Tube	LM358N	
LM358D LM358DT	SO-8	Tube or tape & reel	LM358AN	
LM358YD <sup>(1)</sup> LM358YDT <sup>(1)</sup>	SO-8 Automotive grade		358	
LM358AD LM358ADT	SO-8		358Y	
LM358PT LM358APT	TSSOP8		Tape & reel	358A
LM358YPT <sup>(2)</sup> LM358AYPT <sup>(2)</sup>	TSSOP8 Automotive grade	358		
LM358ST LM358AST	MiniSO-8	358Y		
LM358N LM358AN	DIP8	Tube	LM358N	
LM358D LM358DT	SO-8	Tube or tape & reel	LM358AN	
LM358YD <sup>(1)</sup> LM358YDT <sup>(1)</sup>	SO-8 Automotive grade		358	
LM358AD LM358ADT	SO-8		358Y	
LM358PT LM358APT	TSSOP8		Tape & reel	358A
LM358YPT <sup>(2)</sup> LM358AYPT <sup>(2)</sup>	TSSOP8 Automotive grade	358		
LM358ST LM358AST	MiniSO-8	358Y		
LM358N LM358AN	DIP8	Tube	LM358N	
LM358D LM358DT	SO-8	Tube or tape & reel	LM358AN	
LM358YD <sup>(1)</sup> LM358YDT <sup>(1)</sup>	SO-8 Automotive grade		358	
LM358AD LM358ADT	SO-8		358Y	
LM358PT LM358APT	TSSOP8		Tape & reel	358A
LM358YPT <sup>(2)</sup> LM358AYPT <sup>(2)</sup>	TSSOP8 Automotive grade	358		
LM358ST LM358AST	MiniSO-8	358Y		

1. Qualified and characterized according to AEC Q100 and Q003 or equivalent, advanced screening according to AEC Q001 & Q 002 or equivalent.

2. Qualification and characterization according to AEC Q100 and Q003 or equivalent, advanced screening according to AEC Q001 & Q 002 or equivalent are on-going.

## 8 Revision history

**Table 9. Document revision history**

Date	Revision	Changes
1-Jul-2003	1	First release.
2-Jan-2005	2	$R_{thja}$ and $T_j$ parameters added in AMR <a href="#">Table 1 on page 3</a> .
1-Jul-2005	3	ESD protection inserted in <a href="#">Table 1 on page 3</a> .
5-Oct-2006	4	Added <a href="#">Figure 18: Phase margin vs. capacitive load</a> .
30-Nov-2006	5	Added missing ordering information.
25-Apr-2007	6	Removed LM158A, LM258A and LM358A from document title. Corrected error in MiniSO-8 package data. L1 is 0.004 inch. Added automotive grade order codes in <a href="#">Section 7 on page 17</a> .
12-Feb-2008	7	Corrected $V_{CC}$ max (30V instead of 32V) in operating conditions. Changed presentation of electrical characteristics table. Deleted $V_{opp}$ parameter in electrical characteristics table. Corrected miniSO-8 package information. Corrected temperature range for automotive grade order codes. Updated automotive grade footnotes in order codes table.

**Please Read Carefully:**

Information in this document is provided solely in connection with ST products. STMicroelectronics NV and its subsidiaries ("ST") reserve the right to make changes, corrections, modifications or improvements, to this document, and the products and services described herein at any time, without notice.

All ST products are sold pursuant to ST's terms and conditions of sale.

Purchasers are solely responsible for the choice, selection and use of the ST products and services described herein, and ST assumes no liability whatsoever relating to the choice, selection or use of the ST products and services described herein.

No license, express or implied, by estoppel or otherwise, to any intellectual property rights is granted under this document. If any part of this document refers to any third party products or services it shall not be deemed a license grant by ST for the use of such third party products or services, or any intellectual property contained therein or considered as a warranty covering the use in any manner whatsoever of such third party products or services or any intellectual property contained therein.

**UNLESS OTHERWISE SET FORTH IN ST'S TERMS AND CONDITIONS OF SALE ST DISCLAIMS ANY EXPRESS OR IMPLIED WARRANTY WITH RESPECT TO THE USE AND/OR SALE OF ST PRODUCTS INCLUDING WITHOUT LIMITATION IMPLIED WARRANTIES OF MERCHANTABILITY, FITNESS FOR A PARTICULAR PURPOSE (AND THEIR EQUIVALENTS UNDER THE LAWS OF ANY JURISDICTION), OR INFRINGEMENT OF ANY PATENT, COPYRIGHT OR OTHER INTELLECTUAL PROPERTY RIGHT.**

**UNLESS EXPRESSLY APPROVED IN WRITING BY AN AUTHORIZED ST REPRESENTATIVE, ST PRODUCTS ARE NOT RECOMMENDED, AUTHORIZED OR WARRANTED FOR USE IN MILITARY, AIR CRAFT, SPACE, LIFE SAVING, OR LIFE SUSTAINING APPLICATIONS, NOR IN PRODUCTS OR SYSTEMS WHERE FAILURE OR MALFUNCTION MAY RESULT IN PERSONAL INJURY, DEATH, OR SEVERE PROPERTY OR ENVIRONMENTAL DAMAGE. ST PRODUCTS WHICH ARE NOT SPECIFIED AS "AUTOMOTIVE GRADE" MAY ONLY BE USED IN AUTOMOTIVE APPLICATIONS AT USER'S OWN RISK.**

Resale of ST products with provisions different from the statements and/or technical features set forth in this document shall immediately void any warranty granted by ST for the ST product or service described herein and shall not create or extend in any manner whatsoever, any liability of ST.

ST and the ST logo are trademarks or registered trademarks of ST in various countries.

Information in this document supersedes and replaces all information previously supplied.

The ST logo is a registered trademark of STMicroelectronics. All other names are the property of their respective owners.

© 2008 STMicroelectronics - All rights reserved

STMicroelectronics group of companies

Australia - Belgium - Brazil - Canada - China - Czech Republic - Finland - France - Germany - Hong Kong - India - Israel - Italy - Japan - Malaysia - Malta - Morocco - Singapore - Spain - Sweden - Switzerland - United Kingdom - United States of America

[www.st.com](http://www.st.com)